

State of the Art Race Car Wiring Products



Master Catalog #25

The Leader in Racing Electrical Systems

732.851.5095

www.autorod.net

21 LE VALLEY DR., ENGLISHTOWN, NJ 07726



John Zizza and his son Jason 1988 Street Rod Nationals Louisville Kentucky in 1988

On December 31, 2021, Racing lost one of its true innovators. John Zizza started Auto Rod Controls in 1978 and since that day Auto Rod Controls has been continually designing and manufacturing the finest race car electrical systems on the market. John followed a simple principle for Auto Rod Controls. **Build a quality system that has what racers need and stand behind it for life.** This is what ARC has been doing since 1979.

On May 1st 2022 Auto Rod Controls was taken over by Rich Concato. Auto Rod Controls became the AutoRod Corporation. We will follow the same principles that have guided ARC since 1979 and continue to bring the highest quality products to market that fit the needs of racers and stand behind them.

Rich Concato drag raced for nearly 30 years, as well as owning a very successful Race Car Wiring business, *Concato Racing Custom Wiring* for nearly 20 years. Rich has wired nearly 300 race cars since starting *Concato Racing*. He has been wiring race cars using ARC products almost exclusively.

It is this relationship with John Zizza and ARC that brought about taking it over after John's passing.

Nearly

Nearly 3 years after John's passing, not a day goes by in which his name is not mentioned in the shop. In this time, AutoRod has consistently brought innovative new products to market including, the **60001Z** Control Module, the new **3rd Generation Connection Cable** and the **4000U** Solid State Relay module to name a few. AutoRod Corporation will work tirelessly to maintain the vision that John Zizza had for ARC.

We would like to thank the thousands of customers who have been using ARC products and we look forward to serving you for years to come!

732.851.5095

www.autorod.net

21 LE VALLEY DR., ENGLISHTOWN, NJ 07726



Robbie Gregory's - Pro Street 55 Chevy Belair
Featuring - 6001ZR-WH-ECU, SIM-8, TSM-1

In 1978 ARC saw a need and developed the first race car electrical control. The result was such an advancement in car electrics it was granted the first US Patent for its utilization of high current printed circuitry in automotive power distribution. Later it received a "Best New Performance Product Award" at SEMA 1982.

ARC Developed the First:

- Modular Race Car Electrical System
- The First Nitrous Time Delay
- Digital Display Transbrake Time Display
- Flat Touch Control Panels
- Credit Card Ignition Control
- Nitrous Electrical Control Panel
- High Current Printed Circuit Fusing and Relay Switching Modules

Table of Contents

Flat Touch Controls	4-12
Rocker Switch Systems	13-14
Nitrous Controls	15-16
EFI-ECU Controls & Relays	17-20
Accessories & Replacemnt Parts	21-29
Wiring Aids	30-32
Performance Race Car Plumbing	33

Cover Photo - Phil Cocuzza's Super Stock GT/EA Cobalt
ARC-3700, RC8, Pre Wired

The Flat Touch Series was introduced in 2005 as the Forever Electrics

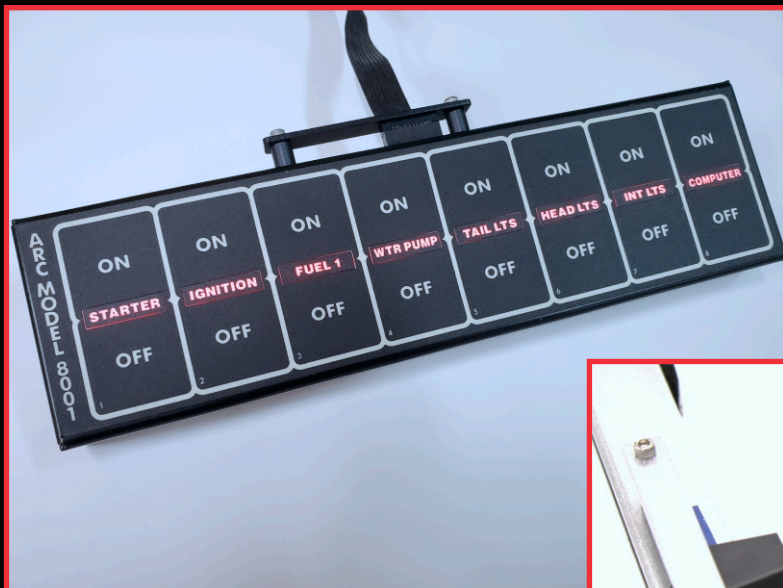

Since then it has seen some changes. In 2017 We introduced the black option and in 2019 we introduced the Pro Mod Series with the Backlit Kill Switch. To date we have sold over 25,000 of these units. Currently it is offered in 4, 8, or 12 Switch Configurations. In 2023 we introduced the 3rd Gen connection cable. This cable eliminates all concerns over the older ribbon cables!

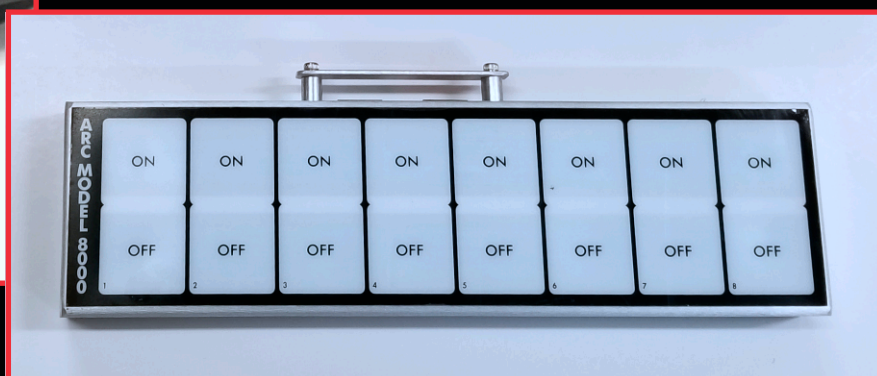

The ARC - 6001Z Series

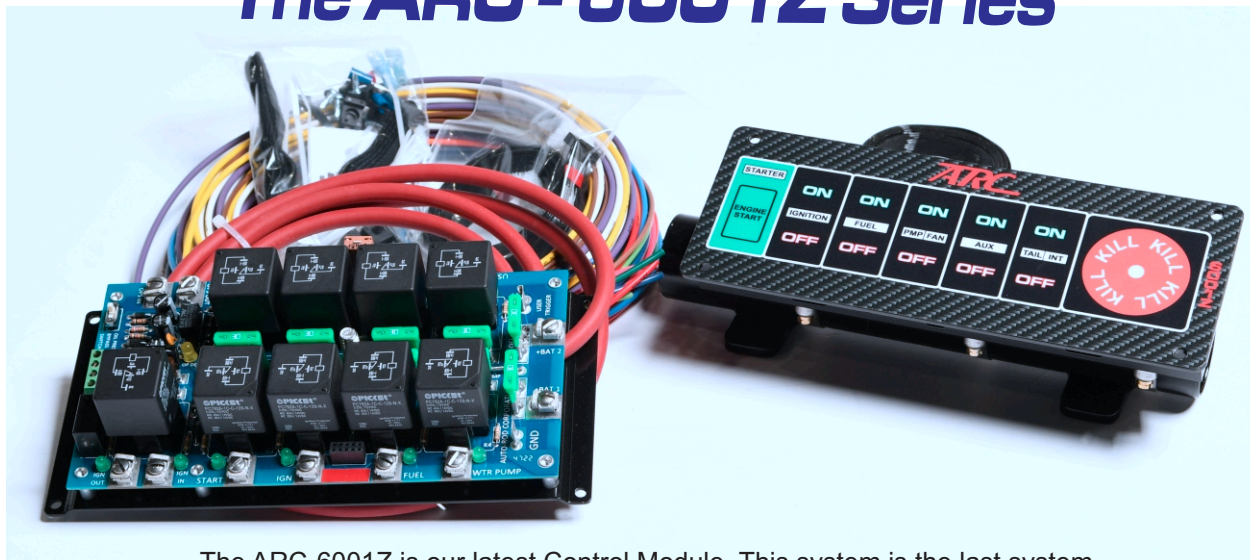

The ARC-6001Z is our latest Control Module. This system is the last system designed by John Zizza before his passing. This system is packed with new features that make it stand head and shoulders above any other system on the market!

This system is designed for both Open Cockpit and Door Cars. This unit is no larger than our 8000 systems but incorporates the Kill switch. This is accomplished through ARC's exclusive dual function Flat Touch switches. One switch controls the Water Pump and Fan. Hit the switch once, it turns on the Water Pump, hit it again to turn the Fan on as well. Both are on individual relays and fuses for protection.

A dual function switch is also used for the Tail Light Circuit. One hit turns on Tail Light, a second hit shuts off Tail Lights and turns on Interior Lights built into the case. See below for a complete list of 6001Z features.

Features Include:

- 40 AMP Replaceable Relays
- Separate Fuses for Each Circuit
- Super Bright LEDs for Open Cockpit Cars
- 6 Second Computer Shutoff Delay
- Dedicated Computer Circuit
- Automatic Low Oil Pressure Shutdown
- Built in Neutral Safety Circuit
- Built in Bump Start Button Circuit
- Built in LED Interior Lights
- Output LEDs for Every Circuit on the Relay Board
- Extra Ground Activated Relay for Any Use
- Printed & Colored Wire for Every Circuit
- 1-5/8" Diameter Backlit Kill Button for Ultimate Safety
- 2 Auxiliary Fused Power Takeoffs
- Most Compact Requiring Less Space Than any Other System
- Available in Panel Mount or Roll bar Mount
- ARC Reliability & LIFETIME WARRANTY
- Switch Panel Measures 8-3/4" L x 3-1/4" W x 1" H
- Relay Board Measures 7-3/4" L x 4-1/8" W x 2-1/4" H

Part Numbers:

6001ZD - Dash Mount
6001ZR - Roll Bar Mount

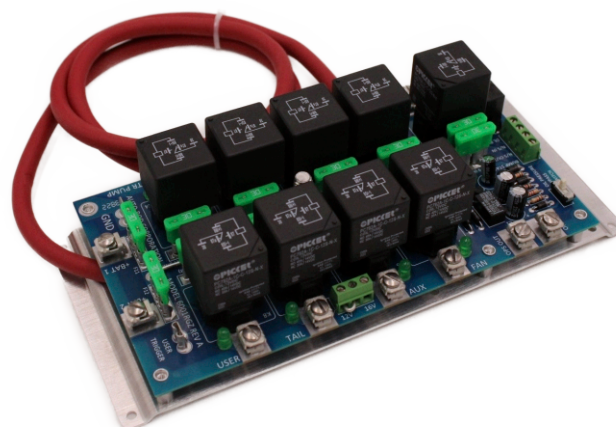

The All New ARC 6001RGZ Relay Board

Forever Electrics/Flat Touch; simply put, any of the products listed in this section come with a complete 100% warranty – **Forever!** That's it – as long as you own this product we will support, replace or repair any problems. You might ask how we can make this lifetime offer? Again, simple answer, our products are manufactured utilizing a strict quality control protocol that requires every unit we produce be thoroughly bench tested for quality prior to shipping. Also, every unit we manufacture is constructed utilizing the highest quality components available.

Some components having an actual tested life cycle of one billion operations.

Part Numbers

4000D - In Dash
4000R - Overhead

8000D - In Dash
8000R - Overhead

12000D - In Dash
12000R - Overhead

Model 12000

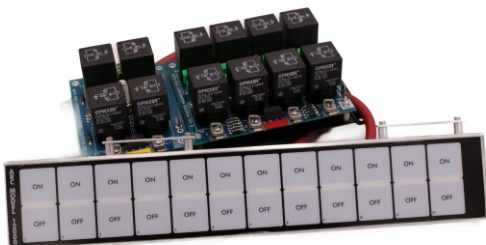

13" L x 2-3/8" H x 3/4" D

Model 8000

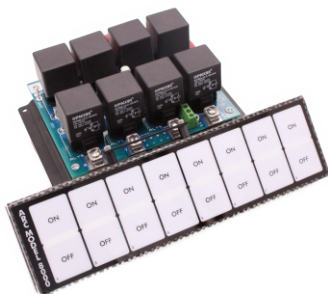

8-5/8" L x 2/3/8" H x 3/4" D

Model 4000

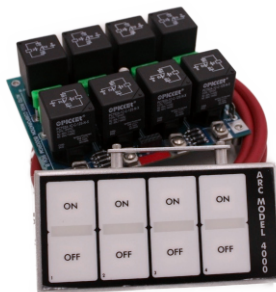

4-7/8" L x 2-3/8" H x 3/4" D

Universal Flat Touch Features

- 11/16" Thick front to back
- LED light bars Red off - Green on
- Library of 58 race & street labels to back light over light bars
- Duplicate words in white to place on relays
- Ability to make any switch location be on/off or push action momentary
- Master kill switch turning off any - none or all of the switches at the same time for ultimate safety
- No dash cutting, Dash mount units Velcro mount to dash. For new flush mount brackets go to accessories
- No bundle of wires coming down the roll bar
- Accepts a firewall keypad which allows you to run the first 4 switches from under the hood
- Cable connector retaining brackets
- The only systems to carry a lifetime warranty
- New-Weatherproof switch panels and relay boards are completely sealed (they'll float) for open cockpit cars. For new weather tight units add -w to the part number
- **Each unit ships with a wiring harness, label kit, and connector kit**



Model 8000 Illuminated

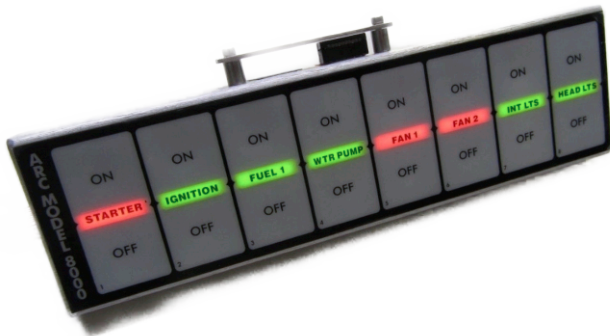

Frosted LED lighting does not have the nighttime glare of pilot lights and lighted rockers. All Flat Touch Units use a Custom 10 Pin Cable to connect the Relay Board to the Switch Panel. This eliminates having to run 8-10 wires all the way to the switch panel.

Firewall Keypad Model 4000F4 & F8 & F12

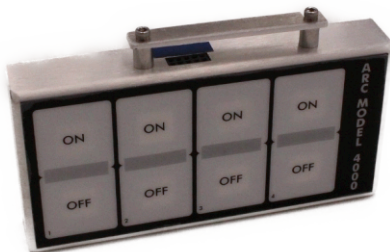

Firewall Keypad Velcros to the firewall plugging into the blue connector on your switch panel and operates the first 4 switches from under the hood
Sealed to be weatherproof.

Part # 4000F4 - mates with Model 4000

Part # 4000F8 - mates with Model 8000

Part # 4000F12 - mates with Model 12000

Part # 4003F4 - mates with Model 4000 (Carbon Finish)

Part # 4003F8 - mates with Model 8000 (Carbon Finish)

Part # 4003F12 - mates with Model 12000 (Carbon Finish)



Programming switches for on/off or momentary and master kill operation. These programming switches can be found on all Flat Touch Models with the exception of the new 6001Z.



Visit [YouTube.com](https://www.youtube.com) to watch video
Search "ARC Flat Touch"
or visit
autorod.net/videos



Wendy Caliendo's NHRA
Stock Eliminator Firebird
Featuring an ARC 8001RPM

Black Flat Touch Systems

Available Models

4001D - In Dash
4001R - Overhead

8001D - In Dash
8001R - Overhead

12001D - In Dash
12001R - Overhead

These units function exactly as previously described in flat touch unit operations. The differences being, only the switch lettering is illuminated and the front is now equipped with night glow, automatically increasing brightness at night to maintain readability even in total darkness.

By reducing light in the car, night vision at the track improves.



Appearance in Daytime

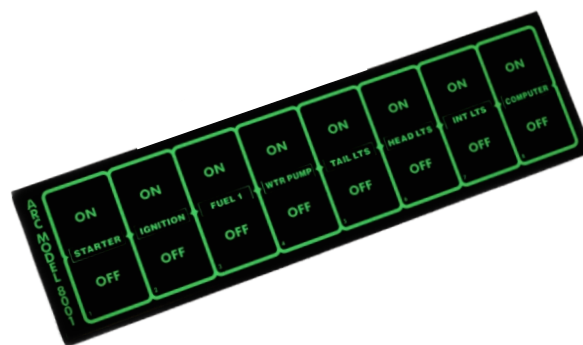

Appearance in Darkness
Self-Activating Night Glow

Actual in Console Installation of Model 8001 and Model 4001

8001 and 4001 Flat Touch units in a console installation using ARC's flush mount brackets (day time and night time photo).

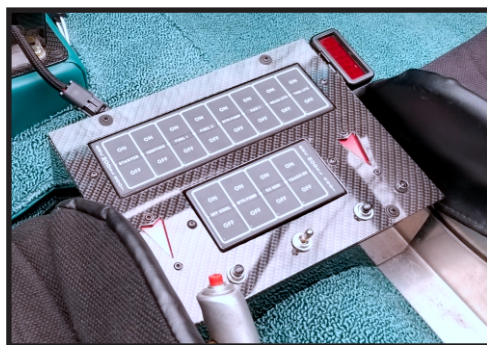

These units are installed using ARC's flush mount dash brackets. They allow for the units to be mounted extending only 1/16th of an inch forward of the dash panel. This photo was taken in the day time.

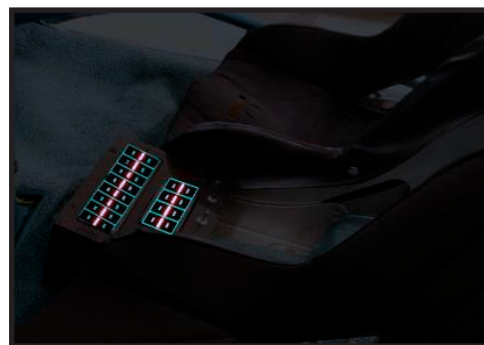

This is the same installation shown with battery power turned on and the unit's night glow feature activated. The front of the panel legend stores light and gives off the energy in the dark. The same way a battery charges and discharges.

Part Numbers

4001D - In Dash
4001R - Overhead

8001D - In Dash
8001R - Overhead

12001D - In Dash
12001R - Overhead

Model 12001

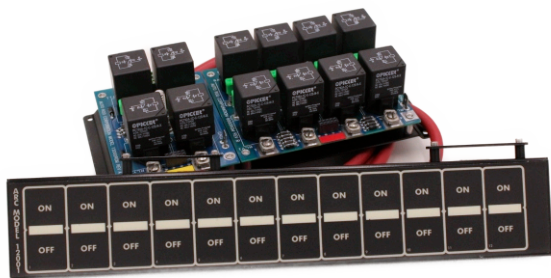

13" L x 2-3/8" H x 3/4" D

Model 8001

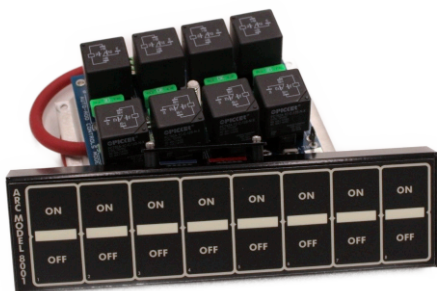

8-5/8" L x 2/3/8" H x 3/4" D

Model 4001

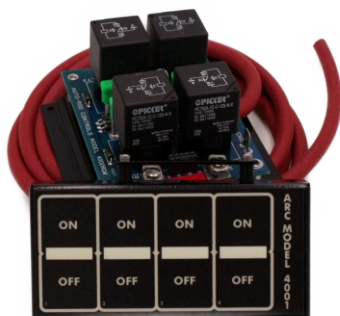

4-7/8" L x 2-3/8" H x 3/4" D

Universal Flat Touch Features

- 11/16" Thick front to back
- LED light bars Red off - Green on
- Library of 58 race & street labels to back light over light bars
- Duplicate words in white to place on relays
- Ability to make any switch location be on/off or push action momentary
- Master kill switch turning off any, none or all of the switches at the same time for ultimate safety
- No dash cutting, Dash mount units Velcro mount to dash. For new flush mount brackets go to accessories
- No bundle of wires coming down the roll bar
- Accepts a firewall keypad which allows you to run the first 4 switches from under the hood
- Cable connector retaining brackets
- The only systems to carry a lifetime warranty
- New-Weatherproof switch panels and relay boards are completely sealed (they'll float) for open cockpit cars. For new weather tight units add -w to the part number
- **Each unit ships with a wiring harness, label kit, and connector kit**





Flat Touch - Carbon

Available Models

4003D - In Dash
4003R - Overhead
4004D - In Dash
4004R - Overhead

8003D - In Dash
8003R - Overhead
8004D - In Dash
8004R - Overhead

12003D - In Dash
12003R - Overhead
12004D - In Dash
12004R - Overhead

These units function exactly as previously described in flat touch unit operations. The differences being, these switch panels are Hydrodipped to simulate a Carbon Fiber Finish. The “xxx3” series is a Carbon Fiber Case with a White Faceplate. The “xxx4” series is a Carbon Fiber Case with a Black Faceplate. The Black units also have our exclusive “NightGlow” feature.



4003, 8003, and 12003
Flat Touch Units



4004, 8004, and 12004
Flat Touch Units

Tech Tip: If you upgrade to a 16V Battery don't forget to move the 12/16 Volt Jumper on our relay board. Also, keep in mind that an accessory on 16 Volts will draw roughly 30-40% more Amperage than it would running on 12 Volts. This can be important information when you convert as you may need to address your alternator if you run one. Check out our Web Site for a comparison sheet! www.utorod.net



Todd Logan's NHRA
Competition Eliminator A/EA Bantam
Featuring 2 - ARC 4001D's

Switch Panels Available Separately

Updating your Race car? Just want a new look? We offer replacement switch panels for all of our units. These are "Plug and Play" with any of our Relay Boards. If you want a Carbon Panel all you need to purchase is a Carbon part number that matches the number of switches you have (4, 8, or 12) and you are ready to go!

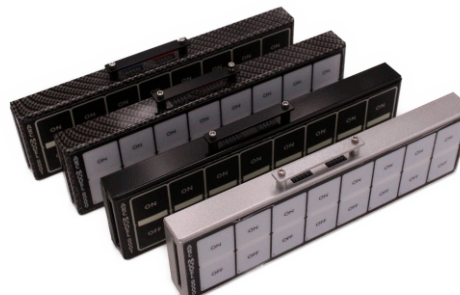

- 4000SD** - In Dash - *Grey Case, White Face Plate*
- 4000SR** - Overhead - *Grey Case, White Face Plate*
- 4001SD** - In Dash - *Black Case, Black Face Plate*
- 4001SR** - Overhead - *Black Case, Black Face Plate*
- 4003SD** - In Dash - *Carbon Case, White Face Plate*
- 4003SR** - Overhead - *Carbon Case, White Face Plate*
- 4004SD** - In Dash - *Carbon Case, Black Face Plate*
- 4004SR** - Overhead - *Carbon Case, Black Face Plate*

- 8000SD** - In Dash - *Grey Case, White Face Plate*
- 8000SR** - Overhead - *Grey Case, White Face Plate*
- 8001SD** - In Dash - *Black Case, Black Face Plate*
- 8001SR** - Overhead - *Black Case, Black Face Plate*
- 8003SD** - In Dash - *Carbon Case, White Face Plate*
- 8003SR** - Overhead - *Carbon Case, White Face Plate*
- 8004SD** - In Dash - *Carbon Case, Black Face Plate*
- 8004SR** - Overhead - *Carbon Case, Black Face Plate*

You can also replace your 4000, 4001, 4003, or 4004 with a Pro Mod Panel with a backlit "Kill" Switch. The same applies to the 8000 and 12000 Units. These too are Plug and Play with no rewiring to do!

Pro Mod Style Switch Panels Only



- 12000SD** - In Dash - *Gray Case, White Face Plate*
- 12000SR** - Overhead - *Gray Case, White Face Plate*
- 12001SD** - In Dash - *Black Case, Black Face Plate*
- 12001SR** - Overhead - *Black Case, Black Face Plate*
- 12003SD** - In Dash - *Carbon Case, White Face Plate*
- 12003SR** - Overhead - *Carbon Case, White Face Plate*
- 12004SD** - In Dash - *Carbon Case, Black Face Plate*
- 12004SR** - Overhead - *Carbon Case, Black Face Plate*

- 4001SD-PM** - In Dash - *Black Case, Black Face Plate*
- 4001SR-PM** - Overhead - *Black Case, Black Face Plate*
- 4004SD-PM** - In Dash - *Carbon Case, Black Face Plate*
- 4004SR-PM** - Overhead - *Carbon Case, Black Face Plate*

- 8001SD-PM** - In Dash - *Black Case, Black Face Plate*
- 8001SR-PM** - Overhead - *Black Case, Black Face Plate*
- 8004SD-PM** - In Dash - *Carbon Case, Black Face Plate*
- 8004SR-PM** - Overhead - *Carbon Case, Black Face Plate*

- 12001SD-PM** - In Dash - *Black Case, Black Face Plate*
- 12001SR-PM** - Overhead - *Black Case, Black Face Plate*
- 12004SD-PM** - In Dash - *Carbon Case, Black Face Plate*
- 12004SR-PM** - Overhead - *Carbon Case, Black Face Plate*

Flat Touch Systems with Low Oil Pressure Shutdown

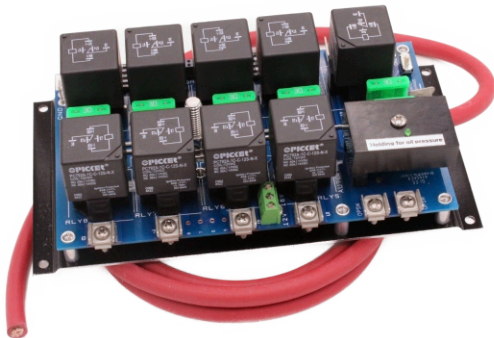

8001RP Relay Board

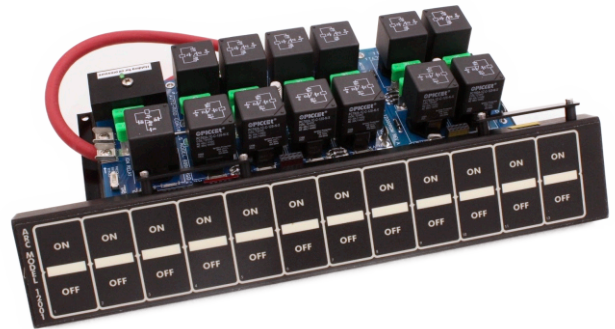

12001RP Flat Touch with Oil Pressure Control

Available Models

- 8000DP** - White front in dash unit
- 8000RP** - White front roll bar unit
- 8001DP** - Black front in dash unit
- 8001RP** - White front in dash unit
- 8003DP** - White front in dash unit (*Carbon Case*)
- 8003RP** - White front roll bar unit (*Carbon Case*)
- 8004DP** - Black front in dash unit (*Carbon Case*)
- 8004RP** - Black front roll bar unit (*Carbon Case*)

Available Models

- 12000DP** - White front in dash unit
- 12000RP** - White front roll bar unit
- 12001DP** - Black front in dash unit
- 12001RP** - Black front roll bar unit
- 12003DP** - White front in dash unit (*Carbon Case*)
- 12003RP** - White front roll bar unit (*Carbon Case*)
- 12004DP** - Black front in dash unit (*Carbon Case*)
- 12004RP** - Black front roll bar unit (*Carbon Case*)

This new system allows starting the engine by temporarily bypassing the oil pressure shutdown feature. When the engine starts it monitors the required low oil pressure. It waits and if minimum oil pressure is not reached safely it will shut engine off. If the pressure is correct the engine will continue to run through the oil pressure switch closure. This overrides the ignition switch on power enabling it to shut the engine off with the ignition switch still on. The ignition switch simultaneously also retains the ability to shut the engine off. With this control the oil pressure switch never switches any high current which assures its longevity while still maintaining a 40 amp capacity ignition circuit.

Our units manual override switch is provided to bypass and/or test the engine oil pressure switch. By automatically monitoring the startup oil pressure rise it is unnecessary to crank the motor excessively with the ignition off in an attempt to obtain enough oil pressure to close the switch and allow the car to start. This procedure only drains the battery, overheats the starter and tends to flood the motor and wash the rings.

The unit works with any two pin normally open contact oil pressure switch.



Pro Mod Flat Touch Systems with Backlit Kill Switch

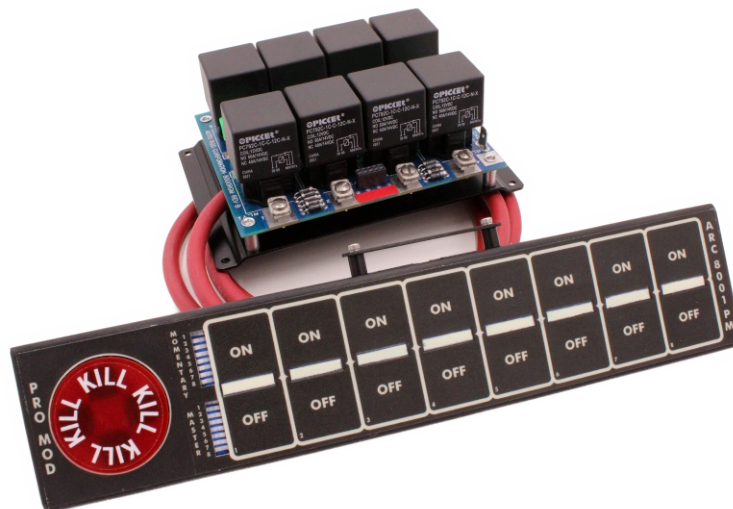

*Pro Mod Flat Touch Controls Available in
4, 8, or 12 Switch Configurations*

4001RPM - Roll bar unit
4001DPM - In dash unit
4004RPM - Roll bar unit
4004DPM - In dash unit

8001RPM - Roll bar unit
8001DPM - In dash unit
8004RPM - Roll bar unit
8004DPM - In dash unit

12001RPM - Roll bar unit
12004RPM - Roll bar unit

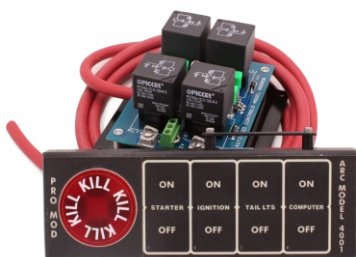

Only available in Black & Black Carbon

This new Pro Mod style system can also be used in other types of cars. This system addresses specific needs of pro mod racers! The two major innovations in this unit are the Translucent Red Lighted system kill switch and the ability to maintain separation between the car's 12 or 16 volt battery and the 24 volt start battery. The kill switch is 1-5/8" in diameter and only requires 1/32" travel to activate and automatically resets.

This is the first system that allows the car to use a 24-volt external starter battery with NO wiring alterations. Other systems require an external relay be added to separate the 24-volt battery from the 12 or 16 volt side of the car. Without this the 24-volt battery source will back feed through the car potentially damaging components or at the very least blow fuses or burn up relays. Our design separates the 12 and 24 volt side permanently, so they can never couple together.

Model PS8



7-3/8" L x 1-7/8" H x 1-5/8" D

Model PS8

Showing back lit switch labels



Power Sticks got their name from the fact that their cross section area is so small that your thumb and for finger will touch when your hand wraps around the unit.



Power Sticks Switch Orientation from left to right

- Starter Switch
- Ignition Switch
- Fuel Pump Switch
- Second fuel pump or accessory switch. By selecting one of two different fuse insertion locations this switch will either draw its power directly from 12V or through the ignition switch
- An accessory switch for any function
- An accessory switch which also activates the "night glow" feature in the unit. Although intended for the operation of dash and taillights it may be used for any function. Te PS8 has two additional accessory switches
- Units are furnished with wiring
- Mounts to dash or roll bar
- Comes with spare switch. Unique split case design makes switch replacement possible in 2-3 minutes
- Easiest to install

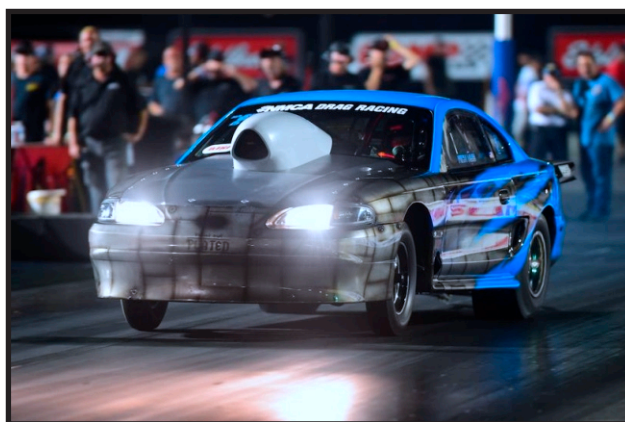

Rich Nye's NMCA
NA/10.5 Mustang
Featuring an ARC 8001RPM-P

PRO STOCK CONTROLS

Overhead and Dash units have the same functions

Starter Switch

Recessed to prevent accidental striking. It is mounted nearest the driver and next to the ignition switch for ease of operation.

Ignition Switch

This switch interlocks to the fuel pump controls shutting the pumps off when ignition is killed. The switch is lighted red when on to aid in night racing.

Fuel Pump Switches

Off in the center position, on in the up position. They are safety interlocked with the ignition switch. The down position is a spring return marked "test" which bypasses the ignition interlock for the purposes of filling the carburetors, setting pressure regulators, and float levels or individually checking pump outputs. Dual switching also allows the use of only one pump in the non-race running conditions saving the batteries. The 2nd switch can also be used for any other function.

Cooling Switch

Designed to operate an electric water pump in the "low cool" position and both an electric water pump and electric radiator fan in the "high cool" position.

Lamps

To allow the gauges and/or headlights to be lighted only when needed extending the bulb life. Units have a three-position lamp switch: off-down, middle-gauges only, and up for gauges and headlights.

Units have a #6 main power cable

Mates to harness part number 3120



Rich Concato's 2002 Camaro
Featuring an ARC 12001RPM

Model 3700 & Model 3710



8" L x 2-5/8" H x 3-1/2" D

Model 3100 & Model 3110

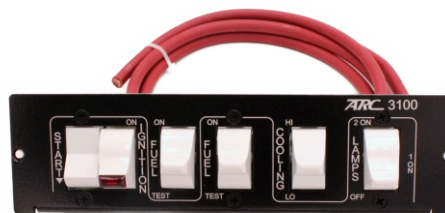

8" L x 2-1/4" H x 2" D

Internal Fuse and Connector Layout



* Both in dash and overhead units hinge out for easy access to fuses. It also contains two spare fuses.

Model 12004R Complete System

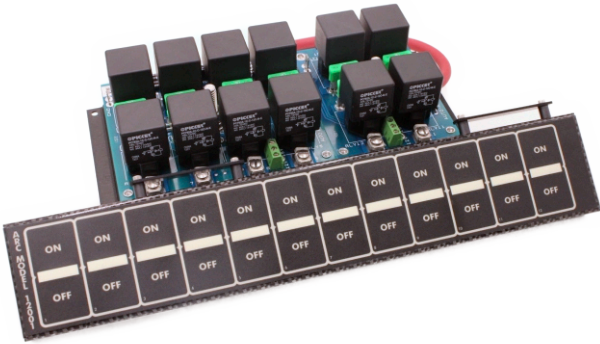

Model 12001-12004 appear here as well as in the section on Flat Touch Controls to demonstrate its unique ability to operate in a nitrous car. It can be configured with a stand-alone nitrous section. Switches 9, 10, 11 and 12 can either be simple on/off switching same as switches 1-8 or using the programming switches at the right side of the unit can be configured to have a second master arm kill switch for your nitrous system. To accommodate the variety of different systems you can have as many purge switches as needed.

Model 3701 - Overhead Pro Stock Control with Nitrous Control System

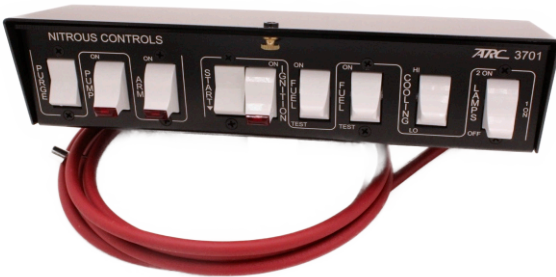

11-3/8" L x 2-5/8" H x 3-1/2" D

Model 3101



5-1/4" L x 2-1/8" H x 2" D

In dash panel nitrous switches. Functions the same as nitrous section in Model 3701

In addition to our standard PRO STOCK CONTROL, this unit includes: LIGHTED ARM, PUMP, and PURGE switching for the control of your nitrous system. The Standard ignition switch activates the nitrous controls. The nitrous section is intended to be used in conjunction with the pump and stage relays part number 1401 listed in this section. Unit works with our harness part number 3120.



Dirk Stratton's
Formula Drift Corvette
Featuring an ARC 4001DPM-ECU

Relay Model 1402 Time Delay Relay

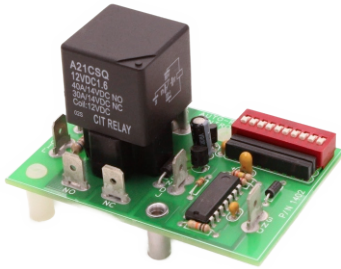

3" L x 2" W x 2-3/16" D

MODEL 1402 - This unit features a plug-in fuse and 40 AMP relay along with an adjustable .1 sec to 1.0 sec time delay in .1 sec increments. It enables you to minimize engine and drive line damage while improving driveability.

EXAMPLES:

Time delay a stage activated by a shifter switch until after driveline loading peaks, the clutch locks up and or the tires hook up.

Activate 2 stages by the same switch, delaying the 2nd stage to lessen motor and driveline stresses and improve traction.

These relays are typically used for pump, purge or stage solenoid operations. These modules feature plug in replaceable fuses and 40 AMP relays and can be operated by switching 12V or ground. Available in one through 5 position units (1401-4 Four position module pictured). Each relay position occupies a 2 x 2 inch space and are 2-3/16 H.

Relay Models 1401-1 through 5

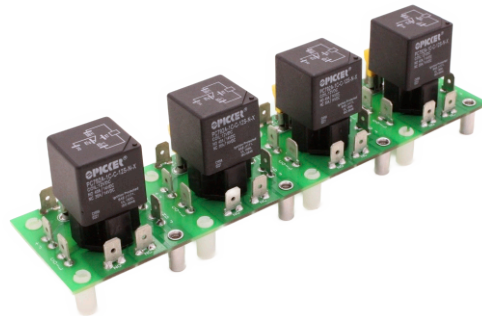

Model 1440 Relay Module



5-1/4" L x 2-3/16" W x 2-1/4" H

This unit contains four 40 AMP plug in relays and input fuse connectors for ATO fuses. This unit also features replaceable lugless connectors. *Relays on this unit are Ground Activated.* Simply connect one terminal of your switch to ground and the other to this relay board or connect your ECU or EFI grounded outputs to operate this module.

80 Amp Relays

This dual position relay board will handle your most demanding loads. Each relay is rated at 80 Amps and can be activated with a Ground or Voltage trigger. Features include:

- Ultra High Current 80 Amp Sealed Relays
- User Selectable Ground or Voltage trigger for each relay
- 70 Amp Maxi-Fuse for each relay
- Led Indicator lamp on each relay output
- 6 gauge power cable
- Flyback protection for ECUs

NEW

Model RC-80 High Current Relay Module

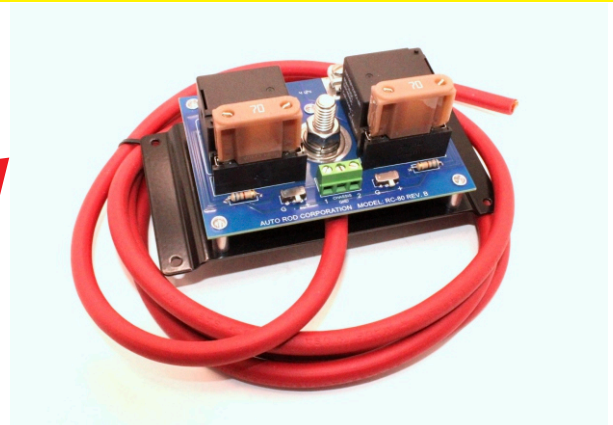

ARC - Universal Relay Boards

The most versatile, feature packed relay boards available

8000U - Universal 8 Relay Controller

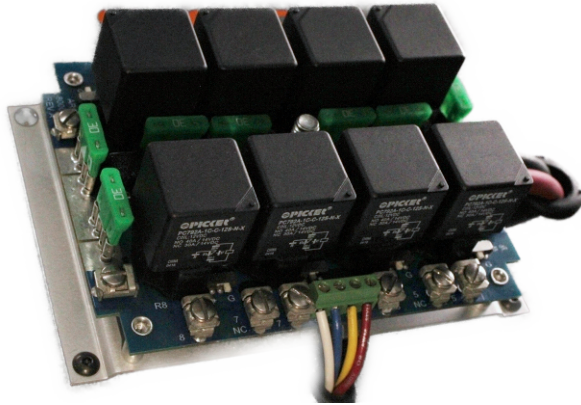

8000U - Universal Relay Controller
6" L x 4-1/8" W x 2-1/4" H

- Selector switches allow any relay to be activated by positive voltage or ground switching.
- 4 Relays have the option of switching high current grounds or high current power.
- All circuits are independently fused.
- All relays have **access to the normally open contact.**
- 4 Relays have access to the normally closed contact.
- 4 Additional fused constant power outputs.
- Custom labeling for all positions.
- All Relays have surge protection for EFI or ECU controls.

4000U - Universal 4 Relay Controller

- **Available with solid state relays**
- 40 Amp sealed mechanical relays standard, up to four ground activated solid state relays optional
- Selector switches allow each relay to be activated by positive voltage or ground (mechanical relay positions only).
- All circuits are independently fused.
- 2 fused constant power outputs.
- Relays have flyback protection to protect EFI/ECU controls
- Includes label set for each relay
- Each Relay output has an LED for ease of troubleshooting

NEW!!

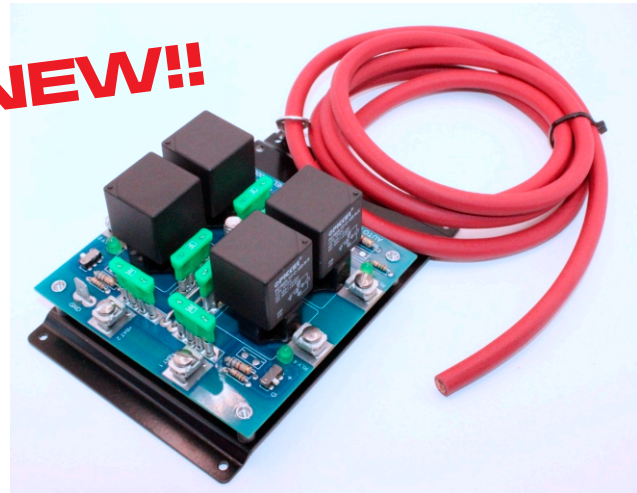

4000U - Universal Relay Controller
6" L x 4-1/8" W x 2-1/4" H



Solid State Part Numbers

- 4000U-SS1 - 1 Solid State Relay
- 4000U-SS2 - 2 Solid State Relays
- 4000U-SS3 - 3 Solid State Relays
- 4000U-SS4 - 4 Solid State Relays

4000U-SS1 will ship with 1 Solid State Relay and 3 Mechanical Relays



Gene Brown's NHRA Super Gas Nova
Featuring an ARC 6001Z - Pre-Wired

Stand Alone Relay Boards

These relay boards have a #6 main power cable and plug in replaceable 40 AMP relays and fuses. All units include custom labeling sheet.

Model RC8

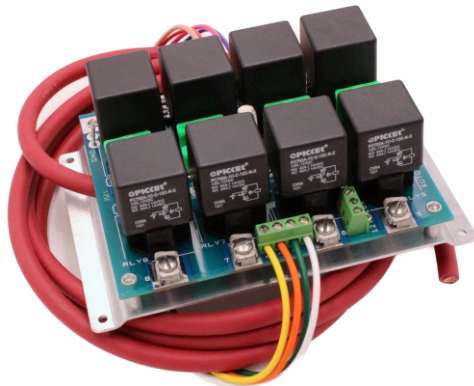

6" L x 4-1/8" W x 2-1/4" H

RC4 - All relays voltage activated
RC4-ECU - All relays ground triggered
RC4-ECU-1 - 2 Relays are Voltage Triggered
and 2 Relays are Ground Triggered

Model Rc4

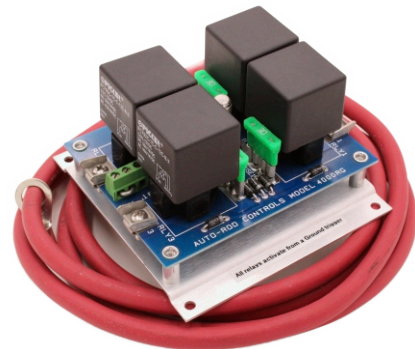

4" L x 4-1/8" W x 2-1/4" H

Model RC-12

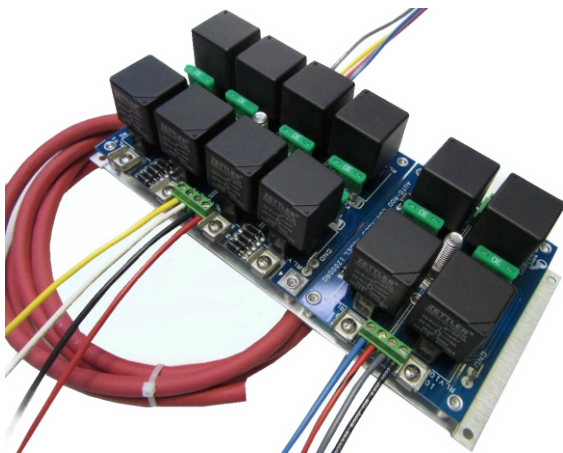

9" L x 4-7/8" W x 2-1/4" H

RC12 - All Relays are Voltage Activated
RC12ECU-1 - All Relays are Ground Activated
RC12ECU-2 - 8 Relays are Ground Activated
and 4 Relays are Voltage Activated
RC12ECU-3 - 8 Relays are Voltage Activated
and 4 Relays are Ground Activated



Roy Finley's N/T Mustang
Featuring an ARC 12001R - Pre-Wired

Flat Touch ECU Systems With ECU Relays

All Flat Touch Ecu Models Feature
Auxiliary Ground Controlled Relays

Model 4000D-ECU

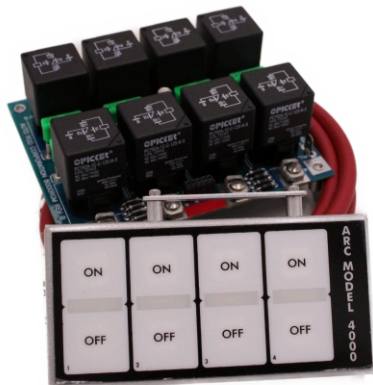

These are available as:

- 4000R - ECU - Rollbar mount – White Face
- 4000D - ECU - Dash mount – White Face
- 4001R - ECU - Rollbar mount – Black Face
- 4001D - ECU - Dash mount – Black Face
- 4003R - ECU - Rollbar mount – White Face, Carbon Case
- 4003D - ECU - Dash mount – White Face, Carbon Case
- 4004R - ECU - Rollbar mount – Black Face, Carbon Case
- 4004D - ECU - Dash mount – Black Face, Carbon Case

Model 8001D-ECU

These are available as:

- 8000R - ECU - Rollbar mount – White Face
- 8000D - ECU - Dash mount – White Face
- 8001R - ECU - Rollbar mount – Black Face
- 8001D - ECU - Dash mount – Black Face
- 8003R - ECU - Rollbar mount – White Face, Carbon Case
- 8003D - ECU - Dash mount – White Face, Carbon Case
- 8004R - ECU - Rollbar mount – Black Face, Carbon Case
- 8004D - ECU - Dash mount – Black Face, Carbon Case

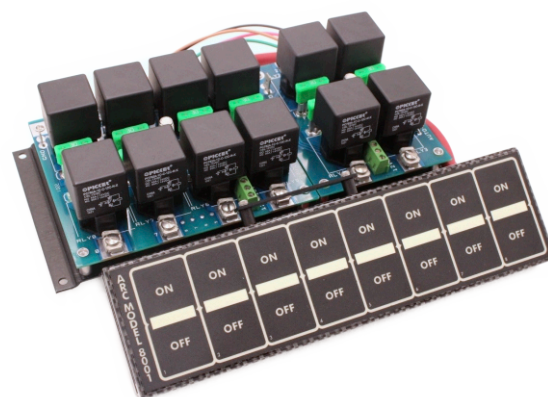

4001 or 8001 Pro Mod with Nitrous Banking Relays

This system is designed specifically for Nitrous Pro Mods using EFI. The kit provides the 8001 Pro Mod Flat Touch System and an additional RC-12 ECU which provides you with 12 Ground Triggered 40 Amp Relays.

These relays can be triggered by the timer functions in almost any ECU. This will allow you to use the ECU to time all of your Nitrous Stages. You can run 1-6 Straight Kits or bank all 6. If you do not bank you can use the remaining relays for any function you choose.

This system is also available with an RC8-ECU (8 Relays)

Model 8001R-PM-12

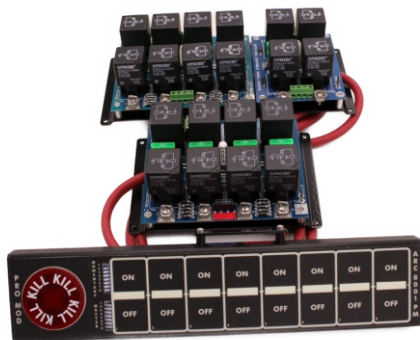

8004R-PM Flat Touch with an RC12-ECU for Nitrous control

Part Numbers

- | | |
|---|---|
| 4001RPM-8 - 4 Switch Unit Plus 4 ECU Relays | 8001RPM-8 - 8 Switch Unit Plus 8 ECU Relays |
| 4001RPM-12 - 4 Switch Unit Plus 8 ECU Relays | 8001RPM-12 - 8 Switch Unit Plus 12 ECU Relays |
| 4004RPM-8 - 4 Switch Unit Plus 4 ECU Relays (Carbon) | 8004RPM-8 - 4 Switch Unit Plus 4 ECU Relays (Carbon) |
| 4004RPM-12 - 4 Switch Unit Plus 8 ECU Relays (Carbon) | 8004RPM-12 - 4 Switch Unit Plus 8 ECU Relays (Carbon) |

Flat Touch ECU Systems With ECU Relays & Oil Pressure Control

4 & 8 Switches - Available in Black or White

Model 4000DP-ECU

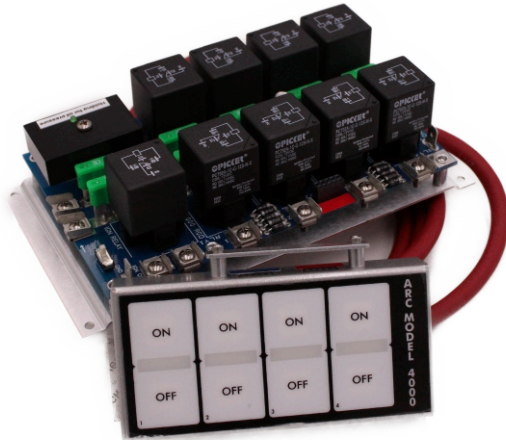

Available Models

- 4000DP-ECU - White front in dash unit
- 4000RP-ECU - White front roll bar unit
- 4001DP-ECU - Black front in dash unit
- 4001RP-ECU - Black Front roll bar unit
- 4003DP-ECU - White front in dash unit (Carbon Case)
- 4003RP-ECU - White front roll bar unit (Carbon Case)
- 4004DP-ECU - Black front in dash unit (Carbon Case)
- 4004RP-ECU - Black Front roll bar unit (Carbon Case)

Available Models

- 8000DP-ECU - White front in dash unit
- 8000RP-ECU - White front roll bar unit
- 8001DP-ECU - Black front in dash unit
- 8001RP-ECU - Black Front roll bar unit
- 8003DP-ECU - White front in dash unit (Carbon Case)
- 8003RP-ECU - White front roll bar unit (Carbon Case)
- 8004DP-ECU - Black front in dash unit (Carbon Case)
- 8004RP-ECU - Black Front roll bar unit (Carbon Case)

Model 8004DP-ECU

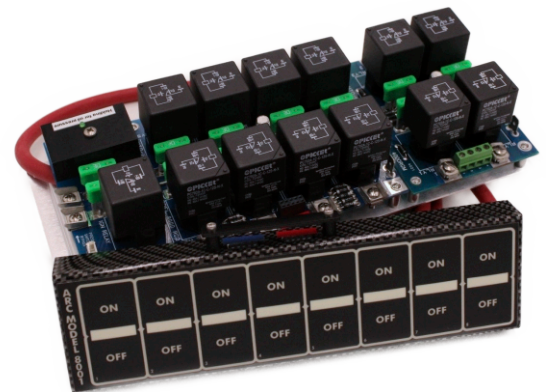

This system allows starting the engine by temporarily bypassing the oil pressure shutdown feature. When the engine starts it monitors the required low oil pressure. It waits and if minimum oil pressure is not reached safely it will shut engine off. If the pressure is correct the engine will continue to run through the oil pressure switch closure. This overrides the ignition switch on power enabling it to shut the engine off with the ignition switch still on. The ignition switch simultaneously also retains the ability to shut the engine off. With this control the oil pressure switch never switches any high currents which assures its longevity while still maintaining a 40 amp capacity ignition circuit.

Our units manual override switch is provided to bypass and/or test the engine oil pressure switch. By automatically monitoring the startup oil pressure rise it is unnecessary to crank the motor excessively with the ignition off in an attempt to obtain enough oil pressure to close the switch and allow the car to start. This procedure only drains the battery, overheats the starter and tends to flood the motor and wash the rings



Pro Mod Flat Touch Systems with Backlit Kill Switch & ECU Controlled Relays

Model 8001RPM-ECU

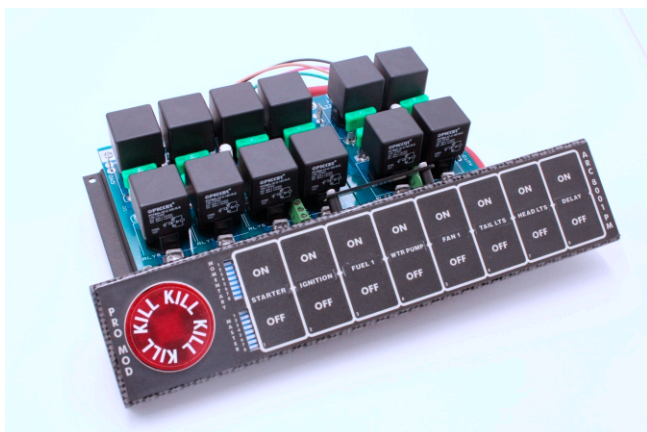

8 Switch Flat Touch with Kill Switch

Part Numbers

4001RPM-ECU - Roll bar unit
4001DPM-ECU - In dash unit
4004RPM-ECU - Roll bar unit
4004DPM-ECU - In dash unit
8001RPM-ECU - Roll bar unit
8001DPM-ECU - In dash unit
8004RPM-ECU - Roll bar unit
8004DPM-ECU - In dash unit

Part Numbers

4001RPMP-ECU - Roll bar unit
4001DPMP-ECU - In dash unit
4004RPMP-ECU - Roll bar unit
4004DPMP-ECU - In dash unit
8001RPMP-ECU - Roll bar unit
8001DPMP-ECU - In dash unit
8004RPMP-ECU - Roll bar unit
8004DPMP-ECU - In dash unit

*These units include 4
ECU Triggered Relays*

Model 8004RPM-P

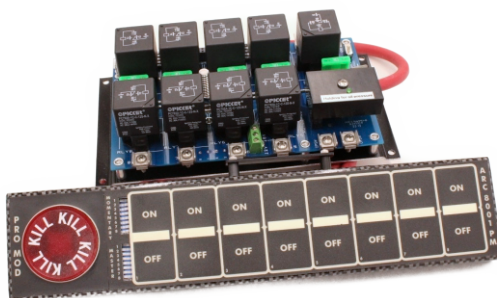

8 Switch Flat Touch with Kill Switch
with Oil Pressure Control

Part Numbers

4001RPMP - Roll bar unit
4001DPMP - In dash unit
4004RPMP - Roll bar unit
4004DPMP - In dash unit
8001RPMP - Roll bar unit
8001DPMP - In dash unit
8004RPMP - Roll bar unit
8004DPMP - In dash unit
12001RPMP - Roll bar unit
12004RPMP - Roll bar unit

*These units include
Oil Pressure Control*



Sal Bellomo's
8.50 Index Camaro
Featuring ARC-8004RPM-P



Visit [YouTube.com](https://www.youtube.com) to watch video
Search "ARC Flat Touch"
or visit
www.autorod.net/videos

NEW!!



NEW!!

The ALL NEW 10 Pin Connector Cable

This cable is compatible with ALL Flat Touch Controls

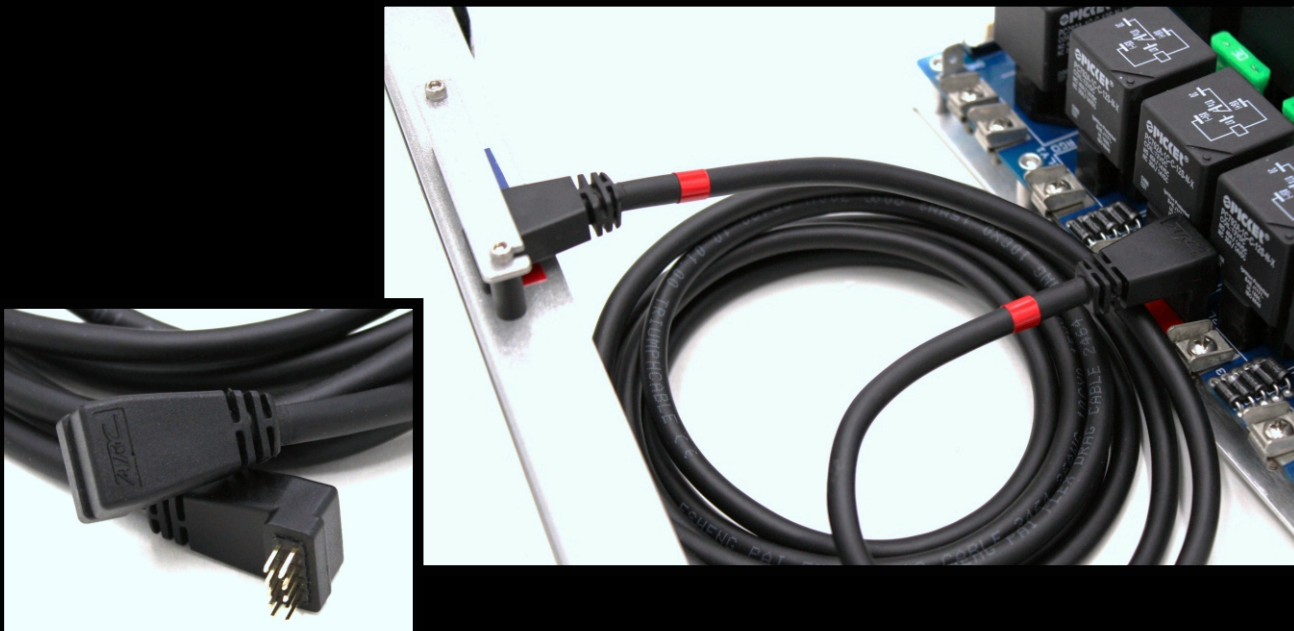

Features Include:

- Overmolded 10 pin connector
- Round Ultra Flexible PVC jacketed cable
- Compatible with ALL existing Flat Touch Controls
- Upgraded design for increased durability
- Includes new cable clamp hardware
- Systems ship with 8' Cable
- 1.5', 2', 3', 4', 6', 10', and 12' Lengths are available

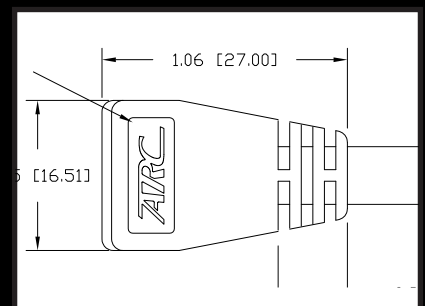

Model 3000

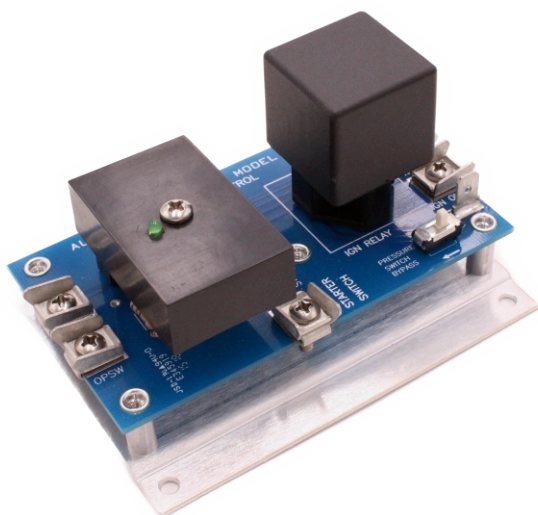

Low Oil Pressure Control

This is a standalone system that will work in any car

This new system allows starting the engine by temporarily bypassing the low oil pressure shutdown feature. When the engine starts it monitors the required low oil pressure. It waits and if minimum oil pressure is not reached safely it will shut the engine off. If the pressure is correct the engine will continue to run through the oil pressure switch closure. This overrides the ignition switch on power, enabling it to shut the engine off with the ignition switch still on. The ignition switch simultaneously also retains the ability to shut the engine off. With this control the oil pressure switch never switches any high currents which assures its longevity while still maintaining a 40 amp capacity ignition circuit.

Our units manual override switch is provided to bypass and/or test the engine oil pressure switch. By automatically monitoring the startup oil pressure rise, it makes it unnecessary to crank the motor excessively with the ignition off in an attempt to obtain enough oil pressure to close the switch and allow the car to start. This procedure only drains the battery, overheats the starter and tends to flood the motor and wash the rings.

This unit works with any two pin normally open contact oil pressure switch.

Oil Pressure Switch Isolator Hose

It is not recommended to thread the Oil Pressure Switch directly into the engine block as the vibration can cause premature failure of the switch.

Our Isolator hose threads into the block with a -03 AN Adapter and the uses a short Stainless Steel Braided Hose to connect the switch.

These hoses are available in the following lengths

Part Numbers

- 3" - OPH-3
- 4" - OPH-4
- 5" - OPH-5
- 6" - OPH-6
- 7" - OPH-7
- 8" - OPH-8

- 03 AN Oil Pressure Tee Fitting - OPT-03B
- 03 AN Oil Pressure Tee Fitting - OPT-03S
- 03 to 1/8" NPT Adapter Fitting - OPA-03

Oil Pressure Control Fittings



Custom Length Hoses are available by Special Order.
Please call us to order.



Lance Knigge's
No Prep/Outlaw Chevy Nova
Featuring an ARC 8001R

**Voltage Reducer
Part # PWM-1612**



Voltage Reducers
6-3/4" L x
1-11/16" W
x 1-1/8" H

**Voltage Reducer
Part # PWM-A**

PWM – 1612
Lowers battery voltage from 16-12V to protect your accessory and lessen battery drain. It has a 30 AMP capacity.

PWMA
This unit has adjustable voltage output in a range from input voltage to zero. It has a 30 AMP capacity.

PWM units work with Electric motors and Incandescent Lights only.
Each reducer model has an internal remote reset circuit breaker. Unit only rises 45 degrees maximum above ambient temperature.

Roll Bar Set Back Brackets

When laying out the driver's cockpit, if you decide the roll bar mounting needs to be closer to the driver, purchase the flat touch dash mount unit and install with the appropriate rollbar Setback Brackets. They are made from .050 Steel. Tack to roll bar and paint to suit.

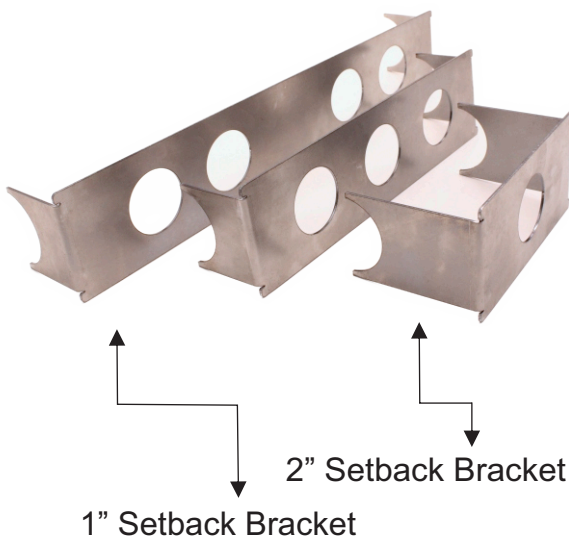

In dash unit shown mounted to Roll bar Setback Bracket

- RS4-1** – for a 4 Switch unit with 1" setback
- RS4-2** – for a 4 Switch unit with 2" setback
- RS8-1** – 8 switch unit with a 1" setback

- RS8-2** - for a 8 Switch unit with a 2" setback
- RS12-1** – for a 12 Switch unit with a 1" setback
- RS12-2** – for a 12 Switch unit with a 2" setback
- RS8-2** - for a 8 Switch unit with a 2" setback
- RS12-1** – for a 12 Switch unit with a 1" setback
- RS12-2** – for a 12 Switch unit with a 2" setback

Flush Mount Dash Brackets

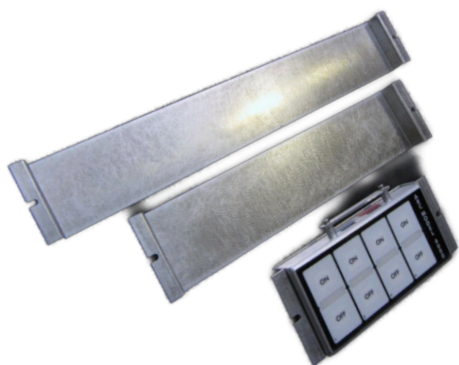

4 Switch unit shown mounted in bracket



TECH TIP:

When wiring your car make sure you use quality Wire and Cable. Saving a few dollars on wire can be a big mistake. It is also important to use the right size wire for the accessory you are wiring in, Wiring can add as little as 20 lbs to your car or a lot more than 20lbs if you do not have the right size wire to work with both big and small!

Replacement Switches - Pro Stock Control Module

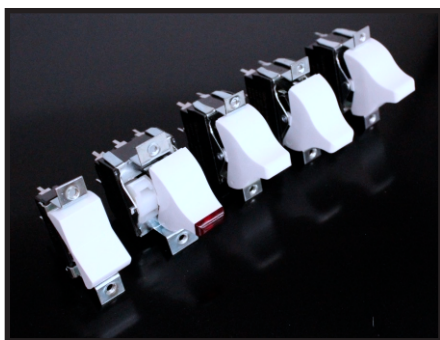

- 2120 - SPST - (Off) (Momentary On) 20 Amp **Starter**
- 2130 - SPST - (On) & SPST (Off) (On) Red Lighted 20 Amp - **Ignition & Fuel**
- 2140 - SPST - (On) (Off) (Momentary On) 20 Amp - **Fuel Pump**
- 2150 - SPST - (Off) (On) & SPDT (On) (Off) (On) - **Fan & Water Pump**
- 2160 - DPDT - (On) (Circuit 1 & 2 On) 20 Amp Progressive Action - **Lighting**

These brackets allow you to flush mount your ARC Flat Touch Units from the rear of the dash. They will require a cutout the size of the face of the unit. The unit will mount the switch panel 1/16 of an inch forward of the dash and is Laser cut in .060" Aluminum.

- 12FM - For a 12 Switch Unit
- 8FM - For a 8 Switch Unit
- 4FM - For a 4 Switch Unit

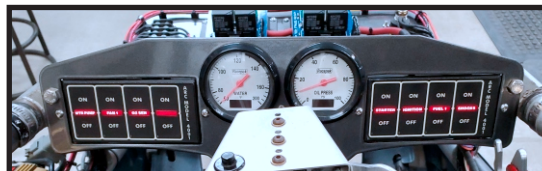

Replacement Power Cables



PC1 - 8' Cable with Threaded Flag Terminal for Rocker Switch Pro Stock Controls

PC2 - 6' Cable with 5/16" Ring Terminal for Flat Touch Controls Relay Boards



Anthony D'Agostino's Nova Super Pro/8.50 Index Featuring an 8001RPM

Pro Stock Harness Part #3120



This harness consists of an 18 ft eleven cable assembly. All wiring is 14 Gauge color coded and oil and gas resistant. Connectors included

Firewall Keypad Cable



RIBBON F - For Firewall Keypad to Switch Panel Connection

Replacement Switches for Powerstick



PSST - Starter Switch
PSSW - All On/Off Switches

Replacement Switch Assembly for Pro Stock Controls

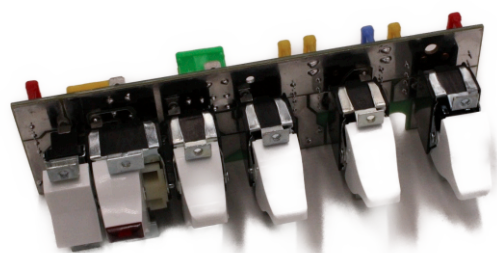

GUTS - Complete internal circuit board, fuse, and switch assembly
N2OGUTS - 3 Nitrous Switch assembly for 3701 Panel

Printed Wire Harness Part #3122



This printed harness consists of 14 and 18 gauge colored wires. All wires are printed every 6 inches for ease of installation and diagnosis.

Plug in Circuit Breaker



Fits into ATO fuse holders
Pop up push button manual reset

1520-5 - 5 Amp	1520-20 - 20 Amp
1520-10 - 10 Amp	1520-25 - 25 Amp
1520-15 - 15 Amp	1520-30 - 30 Amp

Rollbar Conversion Kits for Flat Touch Controls

RB-1 - For 8 and 12 Switch Units
RB2 - For 4 Switch Units



RacePak V-Net Module Mounts

V-Net Module Mount



ARC-VM-01 with 1 Module

RacePak is a Registered Trademark of RacePak Data Systems.

In today's race cars, it is possible for cars to have upwards of 15 **RacePak** Modules in the car. This new product allows racers to neatly and securely mount their V-Net Module in the car.

These V-Net Mounts are available in Black Powder Coat. They are designed to mount up to 5 modules. If you have more than 5 we recommend you use 2.

They are .125" Aluminum so they are very light weight!

Part Numbers

Panel Mount

VM-01

Tube Mount

VM-125

VM-150

VM-162

V-Net Module Tube Mounts



ARC-VM-162 with 2 Modules



ARC-VM-162 with 2 Modules from the Tube Side

V300SD Bulkhead Tube Mount



ARC-RPBM-150 -RacePak V300SD Bulkhead Mount for 1.50" and 1.625" Tubing



Henry Borgers NHRA Super Gas Nova
Featuring an ARC 6001ZR-BL - Pre-Wired

Tech Tip - Grounds in your car are just as important as power! Never assume that the chassis is an adequate ground. When possible, the best practice is to run all ground wires so that they have a direct path to Battery Ground. You can still use the chassis but referencing that chassis ground to the battery ground is the best way.



Replacement Relay Boards

RG4 Replacement Relay Board

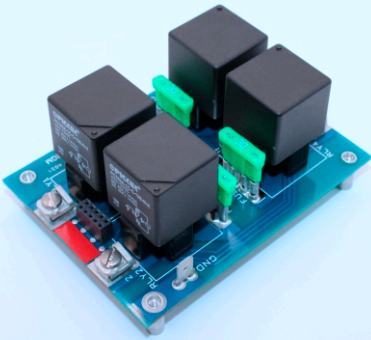

Replacement relay board for 4000 Series Control Modules

We now offer Replacement Relay Boards sold with Relays and Fuses but no power cable

RG12 Replacement Relay Board

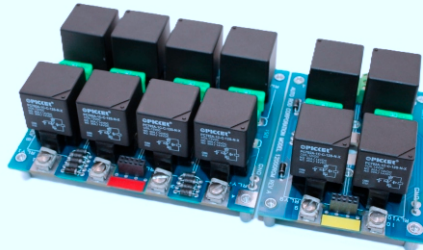

Replacement relay board for 12000 Series Control Modules

RG8 Replacement Relay Board

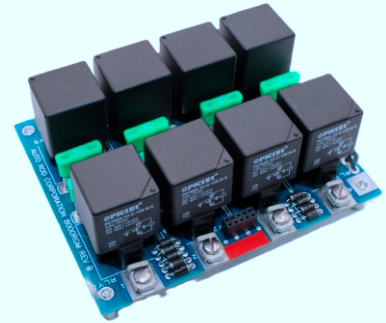

Replacement relay board for 8000 Series Control Modules

6001Z Replacement Relay Board

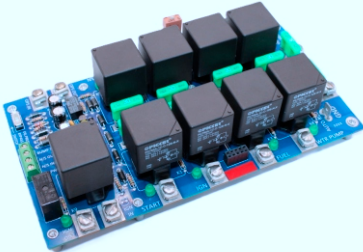

Replacement relay board for 6001Z Series Control Modules

8000P Series Replacement Relay Board

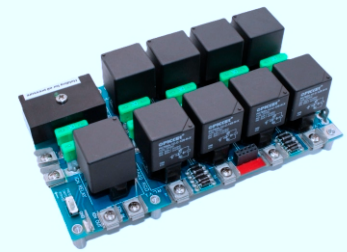

Replacement relay board for 8000 Oil Pressure Control Modules Series Control Modules



Flat Touch Replacement Relays



Replacement relays for ALL Flat Touch Control Modules Sold individually.

Continuous Duty Solenoid



High current Continuous Duty Solenoid

Firewall Keypad Model 4000F4 & F8 & F12

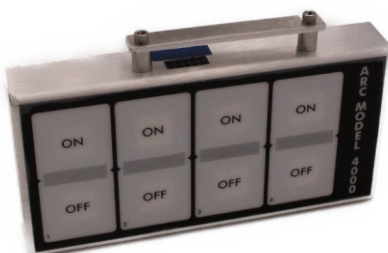

Replacement Cables for Firewall Keypads Part # RIBBONF

Firewall Keypad Velcros to the firewall, plugging into the blue connector on your switch panel and operates the first 4 switches from under the hood. Sealed to be weatherproof.

- Part # 4000F4 - mates with Model 4000
- Part # 4000F8 - mates with Model 8000
- Part # 4000F12 - mates with Model 12000
- Part # 4003F4 - mates with Model 4000 (Carbon Finish)
- Part # 4003F8 - mates with Model 8000 (Carbon Finish)
- Part # 4003F12 - mates with Model 12000 (Carbon Finish)

Custom Label Set

ROOF LTS	REAR LTS	SHIFT	STAGE 3						
O2 SEN	VAC PUMP	TRAN FAN	BOT OPEN	BOT CLO	INT COOL	FOG LTS	AIR COMP	WINCH	
TURN	MTR PURG	BOT WARM	LOGGER	TACH REC	BUMP STA	DATA REC	TWO STEP	STRUTS	
STARTER	IGNITION	IGN-KILL	ARM-KILL	FUEL 1	FUEL 2	WTR PUMP	FAN 1	FAN 2	
DASH LTS	HEAD LTS	TAIL LTS	COMPUTER	LINE LOCK	TRANS BK	NITROUS	NIT FUEL	PURGE	
PURGE	DELAY	FOGGER	SOLENOID	STAGE 1	STAGE 2	SHOCKS	INT LTS	DRIVER FAN	
ALT	RADIO	AMP	CB	OFF ROAD	WIPERS	WASHER	SHIFT	RETARD	

LB1 - for Labeling Switches and Relays

Custom Label Set

ROOF LTS	REAR LTS	SHIFT	STAGE 3						HORN
O2 SEN	VAC PUMP	TRAN FAN	BOT OPEN	BOT CLO	INT COOL	FOG LTS	AIR COMP	WINCH	
TURN	MTR PURG	BOT WARM	LOGGER	TACH REC	BUMP STA	DATA REC	TWO STEP	STRUTS	
STARTER	IGNITION	IGN-KILL	ARM-KILL	FUEL 1	FUEL 2	WTR PUMP	FAN 1	FAN 2	
DASH LTS	HEAD LTS	TAIL LTS	COMPUTER	LINE LOCK	TRANS BK	NITROUS	NIT FUEL	PURGE	
PURGE	DELAY	FOGGER	SOLENOID	STAGE 1	STAGE 2	SHOCKS	INT LTS	DRIVER FAN	
ALT	RADIO	AMP	CB	OFF ROAD	WIPERS	WASHER	SHIFT	RETARD	

LB2 - for Labeling Black Flat Touch Panel

NEW!! - Ribbon Cable Straps



RIBBONST - 10 Straps per Package



NEW!! - Cable Tie Bases

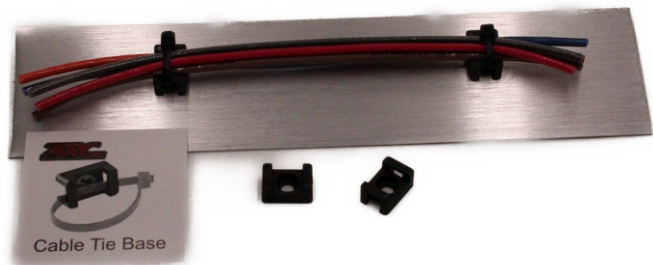

CTB-20 - 20 Bases per Package



Mike Grafas' NHRA Top Sportsman Corvette
Featuring an ARC 8004RPM-P

Model TSM-1

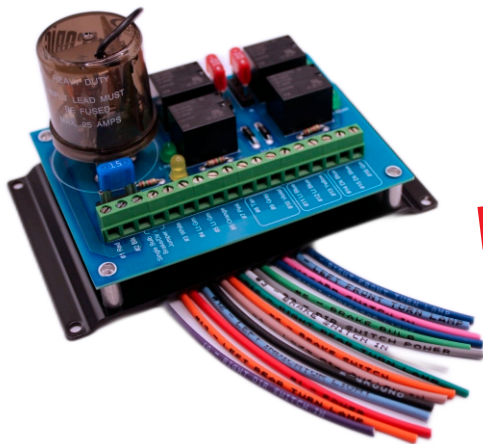

NEW!!

Turn Signal Control Module

This is a standalone system that will work in any car

The new **ARC-TSM-1** is your complete solution for adding Brake Lights, Turn Signals, and Hazard Lights. This completely stand alone unit can be used with Toggle Switches, or some aftermarket Turn Signal Switches. It uses any standard Brake Light switch, and any toggle switch can control the Hazard Lights as well.

The **TSM-1** is Fuse protected and ships with Printed wire for easy installation. It also ships with a High Current LED compatible Flasher.

Ships with panel mount Hazard and Directional Switches

NEW!!

Sensor Integration Module Sensor Integration Module-ECU

The ARC **SIM-8** and the **SIM-8-ECU** are specifically designed for EFI applications, in which the user wants to wire multiple sensors back to the ECU. Until now, this has been a cumbersome process as every sensor requires a Sensor Power, Sensor Ground, and a Sensor Signal to the ECU.

This product allows you to clean this up by bringing a single Sensor Power and Ground to our board and it is distributed through the circuit board to handle up to 8 individual sensors. Included with the **SIM-8** is a 10-conductor shielded wire which carries Power and Ground as well as 8 individual inputs to the ECU. The **SIM-8** also has a diagnostic LED which will light when sensor power is present at the board.

The **SIM-8** can also be helpful in troubleshooting connectivity issues. For example, if you are not sure if a particular input you have assigned is working correctly you can simply move the sensor to a different terminal on the **SIM-8** and just assign a new input for diagnostic purposes.

The **SIM-8-ECU** is the same part but it has 4 Ground triggered relays on the same board as well. Simply bring a ground output from the ECU to the **SIM-8-ECU** and you will have a 40 Amp relay at your disposal for any accessory you choose, up to 4.

Model SIM-8

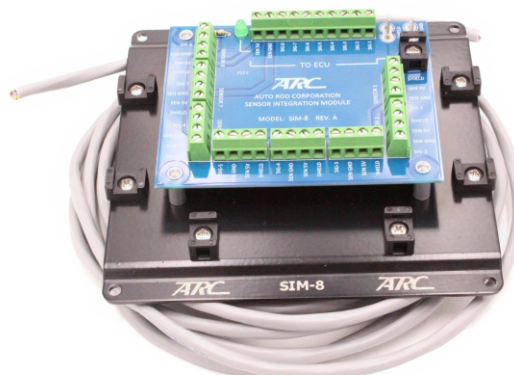

Model SIM-8-ECU

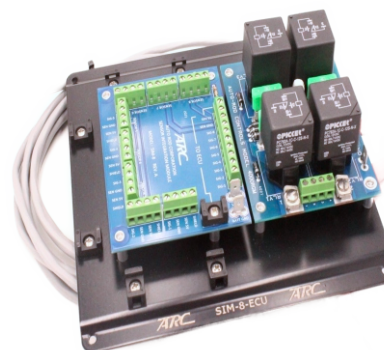

Kenny Capraun's Front Engine Dragster
Featuring An ARC 4001D

Model - Crimp Kit Terminal Crimping Kit

This kit includes ALL the crimp tools you will need to wire your car. This kit includes the removal tools as well.



Model - Mounting Panel

Electronics Mounting Panel

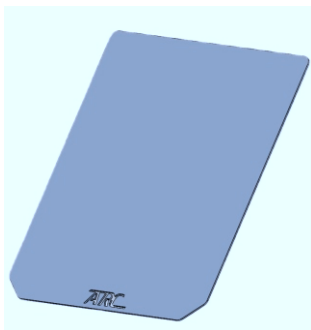

ARC can custom design a panel to mount all of your electronics. These can be designed using your measurements or you can choose from a library of designs for specific cars. They are laser cut in .125" Aluminum and Powder coated Black.

Model - 75 Amp Relay

High Current Relay



This high current relay can be used with any accessory with a high current draw up to 75 Amps continuous. Sold with or without a wiring harness.



Model - Deutsch Connectors

DT and DTP Series

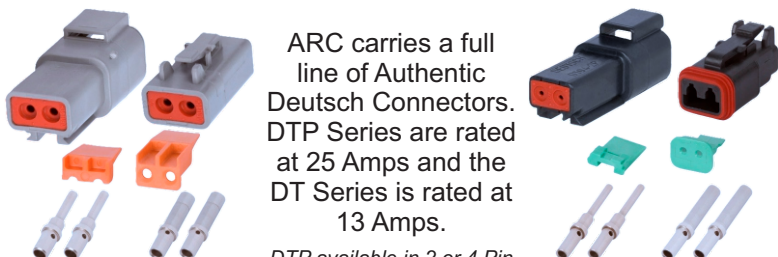

ARC carries a full line of Authentic Deutsch Connectors. DTP Series are rated at 25 Amps and the DT Series is rated at 13 Amps.

DTP available in 2 or 4 Pin
DT available in 2,3,4,6,8,12 Pin

Model - Terminal Strips

2-18 Position Terminal Blocks

These Terminal Strips make connecting multiple wires to the same circuit a breeze. Available in: 2-18 positions.



Model - Insulated Studs

Insulated Battery Posts



These insulated Studs are perfect for bringing power and ground to the front of the race car.

Sold individually, Red or Black

Model - Terminal Kit

Wiring Terminals & Shrink Tube



This kit supplies all the terminals you need to wire your car. These uninsulated, brazed seam terminals require the use of the included shrink tube kit.

Model - Wiring Kit

New Install Wiring Kit



ARC Wiring Terminal Kit
ARC Heat Shrink Tube Kit
Remote Starter Solenoid
Insulated Power and Ground Studs
Firewall Bump Start Switches
14 Position Terminal Strip
25 Cable Tie Bases with Hardware



Lee Zane's NHRA Bracket Apollo
Featuring an ARC 6001Z

Custom Electrical Panels

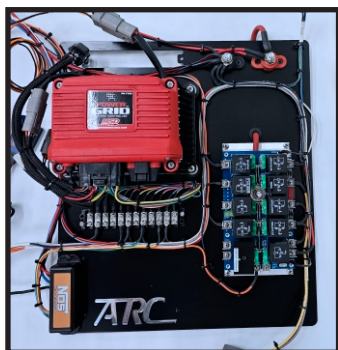

G-Body Panel

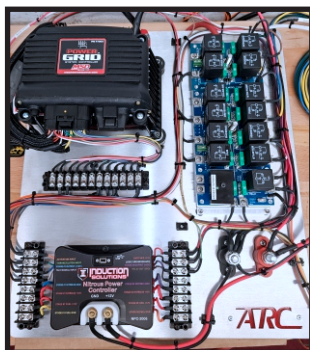

S-10 Panel

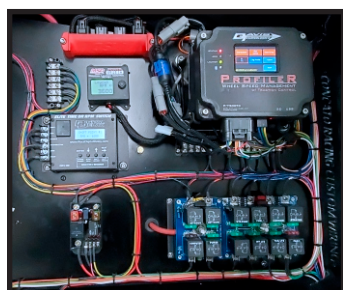

70-81 Camaro Panel

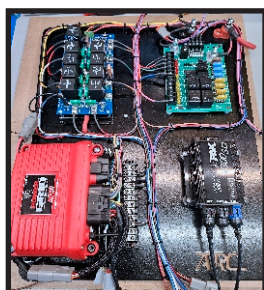

Dragster Panel

Material Options Include:

Aluminum
Carbon Fiber
Lexan
Titanium

Finish Options Include:

Paint
Powdercoat
Hydro Dipped

This product takes all the guessing out of building an electronics panel for your Race Car. Through years of experience we offer C.A.D. designed panels built for your car and for all the electronics that you need mounted. These panels are designed to fit your car and allow you to have one panel with ALL of your electrical components mounted to it!

The panels are Designed in Solid Works and cut by Laser for a nice clean smooth finish. The panels can be cut from a wide variety of materials including Aluminum, Lexan, and Carbon Fiber. We have an extensive library of panels that fit in many different cars. If we do not have one for your car we can design one custom for your car.

The panels are designed to be lightweight yet rigid enough to allow the mounting of all components. We remove the material below the components to keep them as light as possible as well.

Due to the custom nature of this product, pricing is only available on a per job basis.

Panel pricing depends on the size, cut complexity, material, and finish. We offer a wide variety of finish options. If you do not have the components you need we can supply them as part of the job and you can receive your panel cut, assembled, and ready to install. Finally, we can also pre-wire this panel as well which will save you significant time in the wiring of your car.



Dwight Ausmus' N/A 10.5 Camaro
Featuring an ARC 6001Z and Pre-Wired Panel



Please contact us for this service at 732-851-5095



AutoRod Corporation also offers performance RaceCar Plumbing with Hose and Fittings supplied by BMRS. This is the highest quality hose and the highest quality fittings available today! These hoses are Crimped using the BMRS Crimp machine as shown and crimped within .004” of the recommend final crimp measurement.

We have a full line of fittings and hose. All hose is PTFE and adequate for almost any fluid. The fittings are available in -02 thru -20 AN sizes in many different angles.

This service is custom. To order any hoses please contact ARC directly at 732-851-5095.



Aramid Fiber Hose & 180 Degree Swivel Fitting

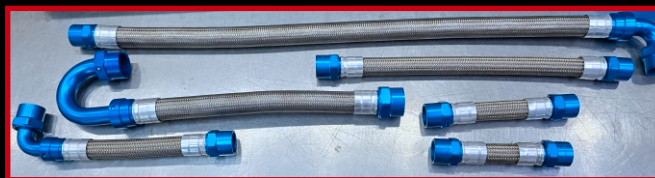

SS Braid Hoses Swivel Fittings in Blue



SS Braid Hose & 60 Degree Swivel Fitting



BMRS Crimp Machine



Marty Rinehart's NHRA
Super Stock - SS/EA Camaro
Featuring An ARC 12001RPM

Contact Information

AutoRod Corporation - South

207 Mistr Lane
Pickens, SC 29671
732.851.5095
Rich@AutoRod.net

AutoRod Corporation - North

385 Mendell Rd
Rochester, MA 02770
774-417-6542
[Contact@AutoRod.net](mailto>Contact@AutoRod.net)

Please direct any returns to NJ or MA

AutoRod Corporation - Headquarters

21 Le Valley Drive
Englishtown, NJ 07726
732.851.5095
Rich@AutoRod.net



*Kevin Sensi's - Drag and Drive Camaro
Featuring an 8001RPM-P-ECU, SIM-8, 4000U-SS2, TSM-1*

21 Le Valley Dr., Englishtown, NJ 07726